

Saarioinen Sahalahti HP-unit

Ruoka-Saarioinen Oy

The factories of Ruoka-Saarioinen Oy (turnover 158 MEUR), which is part of the Saarioinen Group, are located in Sahalahti, in the municipality of Kangasala. The factories produce 140 tons/day in product groups such as casserole foods, chicken products, semi-finished frozen foods as well as meat and sauce foods.

Utilizing waste heat in the heating of driving water and premises

A 2009 installed Scancool industrial heat pump utilizes the waste heat generated in the cool production at a factory of Ruoka-Saarioinen. The recovered energy is used to heat the premises and to heat driving water up to 60°C.

Key figures of the HP291 unit:

- Maximum capacity of the 2-circuit heat pump: 1.4MW
- COP 5.0
- Heat source: condensing NH₃ 9 bar
- Programmable PLC automation
- Estimated payback time: 1.7 years

In addition to the savings generated by a considerably lower oil consumption, the unit decreases carbon dioxide releases by 1400 tons a year.

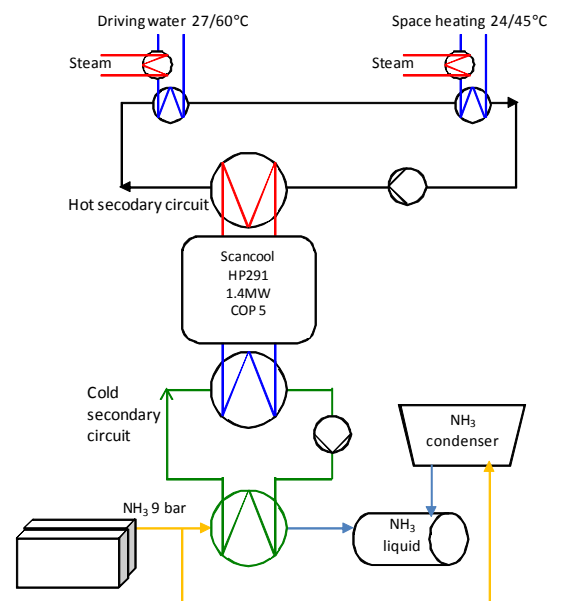

A conceptual view of the heat pump system.

Scancool heat pumps

- a better choice

- ✓ Ready to be used with district heating
 - can produce 80°C water
 - thermal power 0.1 – 10 MW
- ✓ Innovative process solutions, client-specific detailed design and high-quality components guarantee optimal performance
- ✓ The module-based heat pump system can easily be extended
 - module breadth 1.2m, length 2.4m, height 1.6m
 - module thermal power 0.1 – 1 MW



The HP-unit supplied to Sahalahti.

www.scancool.fi



Keeping You Cool

KOKKOLA
Yrittäjätie 6
67100 KOKKOLA
Tel. +358 207 281 868

PIETARSAARI
Havutie 3
68600 PIETARSAARI
Tel. +358 207 281 868

SEINÄJOKI
PL 376
60101 SEINÄJOKI
Tel. +358 207 281 868

TAMPERE
Pinninkatu 53 B
33100 TAMPERE
Tel. +358 207 281 868

TUUSULA
Majavantie 10
04320 TUUSULA
Tel. +358 207 281 868